

CEZOS

LFM 701 WW

LW362518L701W



INTRODUCTION

LFM 701 WW is an advanced generator for fiber optic. Using newest technology we provide the best solution for lighting control. Industrial connectors provide quick installation of the entire lighting system.

Description	LFM 701 WW
Article Number	LW362518L701W
Dimension	124x72x57 mm
Power Supply Type	Constant Current (CC)
Power	15,5 W
Nominal Current	700 mA
Number of LEDs	7 pcs
Luminous Flux	1260 lm @ 3000K
Protection	IP 20
Diameter of Fiber Port	30 mm
Max Ambient Temperature	40°C

FEATURES

Advantage of LFM 701 WW is generator of warm white light. Generator is specially designed to power fiber optic.

- Industrial connectors for quick and simple wiring
- Simple installation
- Low power consumption
- High life expectancy
- Directed light beam, special designed for fiber optics
- Number of fiber optic 1000 x 0.75 mm²
- Solid housing
- No colour filters inside
- Shockproof

APPLICATIONS

- Accent and Effect Lighting
- Professional lighting
- Shop lighting
- Advanced illuminations
- Night sky

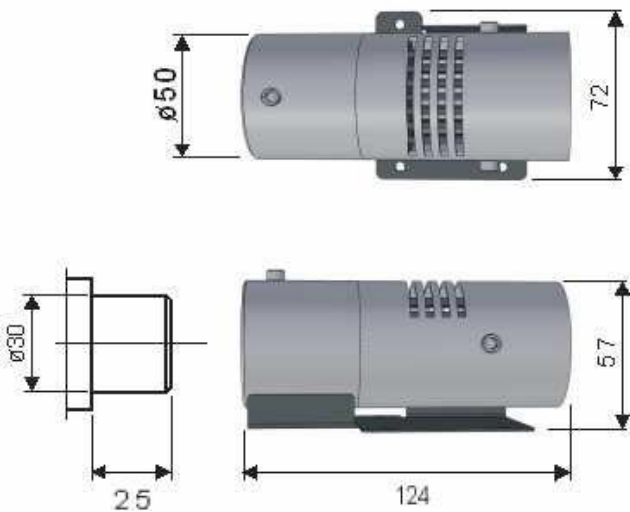

LFM

LFM 701 WW is specialized LED light generator to power fibre optic. These generators are high power up to 15,5 W. Fiber optic port allow to connect 1000 fibers with a diameter of 0,75 mm². LFM hasn't built-in colour filter.

SAFETY

Generators may changes light intensity, but even dimmed LEDs generate high intensity light. Looking into LEDs beam is unhealthy and may cause irreversible injury to eye's retina. Never look into the beam without protection glasses with appropriate filter. Additionally they may change LEDs light intensity almost immediately. If people are photosensitive, LEDs light may be a trigger to epileptic seizures and alter the perception, especially when light change very fast.

Generator can work on high power supply current, so never touch components and wires of controller when power supply is on.

PROTECTION MEASURES AGAINST DAMAGE

Generator are delicate, even small mechanical stress may damage generator. Such stresses should be avoided. If it is impossible, it should be kept to minimum. Mechanical stresses such as pressure, bending, breaking, drilling, etc. may cause irreversible damage. Damaged generator aren't suitable for use.

Do not open housing and touch electronic components.

Additionally generators can be damaged by some chemical substances. Depends of elements the damage may be different. It is important not to use chemical substances like acids, organic acids, sulphur, alkalis, organic solvents, mineral oils, vegetable oils and synthetic oils, etc. We are not responsible for any loss, or damage resulting from improper use of generator! Guarantee become void in such cases.

Do not operate generators, when they aren't working properly. If generators are working incorrectly, turn off power supply. Damaged generator may cause electric shock or short circuit.

CONNECTIONS

The generator and driver must be operated by suitable power supply. When connecting a few drivers and generators use of appropriate power supply is important. Power supply should have sufficient max. power to maintain all drivers and generators. Power supply must be connected properly. Wrong polarization can destroy drivers and generators in very short time. Thanks to LFM 701 WW it is possible to change intensity of light that power fiber optics. We are not responsible for any loss, or damage resulting from improper use of driver and generator! Guarantee become void in such cases.

WIRING DIAGRAM FOR LFM 701 WW

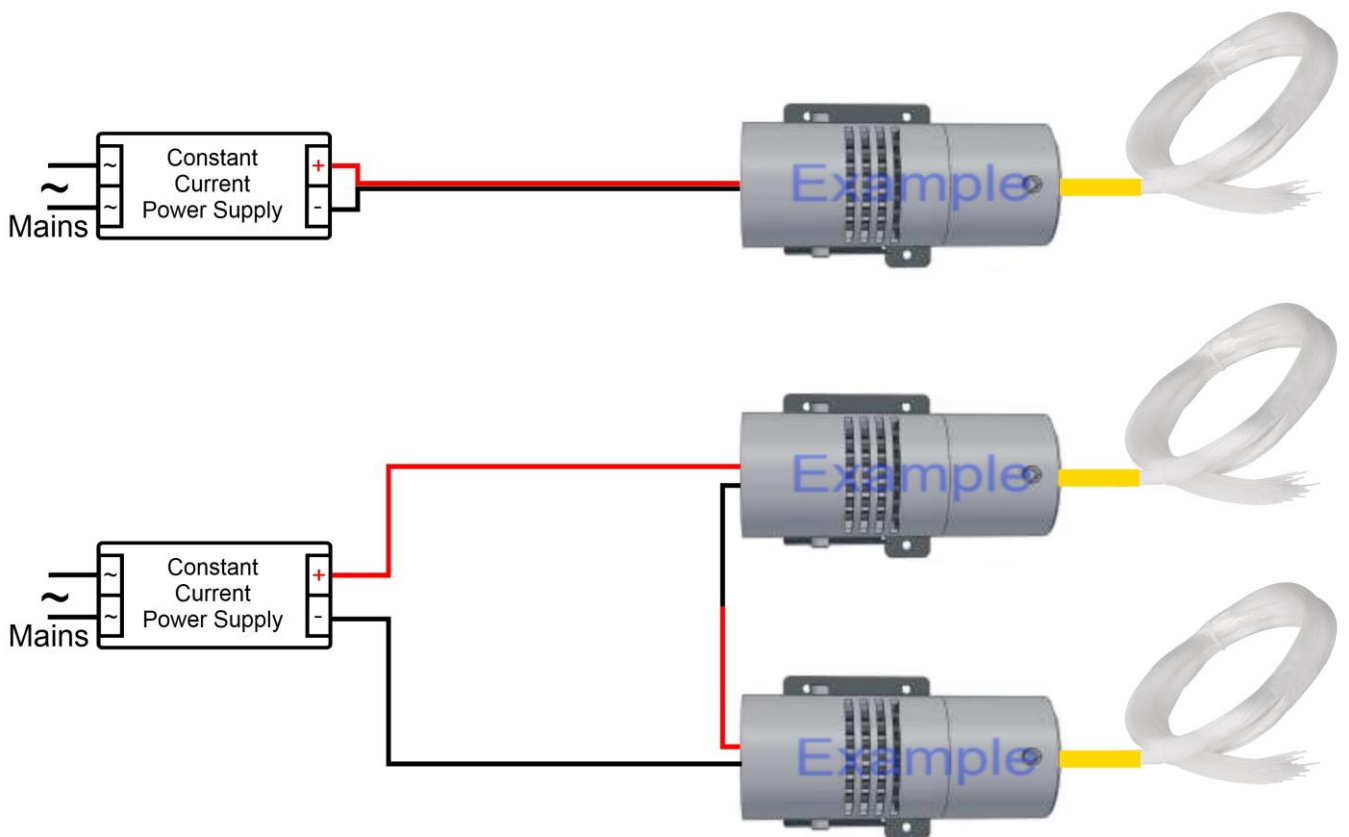

LFM can be connected only with serial wiring. LFM may be connected to driver. Above connection is examples and may be different from the actual.

COOLING

Generator produces heat. They must be provided with good air ventilation. Generator without air ventilation can overheat. Overheat can damage or destroy some elements or entire generator. We are not responsible for any loss, or damage resulting from improper use of drives! Guarantee become void in such cases.

STANDARDS AND DIRECTIVES

In the process of designing and manufacturing the following standards and directives were taken into account:

- 2006/95/EC – Low-voltage Directive: electrical equipment for use within certain voltage limits
- 2004/108/EC – EMC Directive: electromagnetic compatibility
- 2011/65/EC – RoHS Directive: restriction of hazardous substances in electrical and electronic equipment
- DIN IEC 62031:2008 – Safety requirements for LED modules
- EN 60598-1:2008 and A11:2009 – General requirements and tests for luminaires
- EN 60598-2-2:1996 and A1:1997 – Luminaires - Part 2. Special requirements; Main section 2: Recessed luminaires
- EN 62471:2008 – Photo-biological safety of lamps and lamps systems
- EN 61347-1:2009 – General and safety requirements
- EN 61347-2-13:2007 – Special requirements for DC and AC powered electronic operating equipment for LED modules
- EU Regulation No: 874/2012 – Energy labelling of electrical lamps and luminaries

CONTACT

CEZOS

81-534 Gdynia POLAND,

Olgiarda 88/b

tel. +48 58 664 88 61

cezos@cezos.com

www.cezos.com

Subject to technical changes and errors.